

# S37

## SAFETY RELIEF VALVE

**3/8"** UP TO **40 BAR 580 PSI**

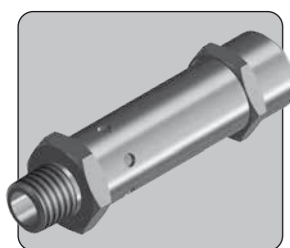

The S37 is a vent to atmosphere safety relief valve. Designed with an elastomeric seat seal the valve combines excellent leakage performance with a high discharge flow capacity from its pop-open characteristic.

The valve is approved as a safety accessory to category IV of the Pressure Equipment Directive, and is suitable for use in the most demanding liquid or gas applications.

- Approved to category IV of the Pressure Equipment Directive (2014/68/EU)
- Pop-open characteristic for maximum discharge capacity
- Vents to atmosphere – no need for exhaust side pipework
- Available preset and internally adjustable. Wire locking and tagging available on request
- Available with relieving gear to enable manual release of pressure
- Virtually zero leakage at 90% of set pressure
- Reseat within the greater of 5 psi or 7.5% of set pressure when valve has opened and not popped
- Reseat within 50% of set pressure once popped
- Repeatability within the greater of 2 psi or ±3% of nominal set pressure

### Specifications

**BASIC MODEL NUMBER**

**S37**

**SYMBOL**

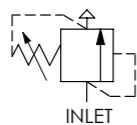

**MAX WORKING PRESSURE**

40 bar  
(580 psi)

**ORIFICE SIZE**

Ø9.8mm  
(Ø0.386")

**FLUID**

Liquids and Gases  
See materials section

**TEMPERATURE RANGE**

See Product Selector opposite  
and Technical Data section

**PORT SIZE**

3/8"

**WEIGHT**

0.2 kg  
(0.4 lb)

Specifications may change without notice

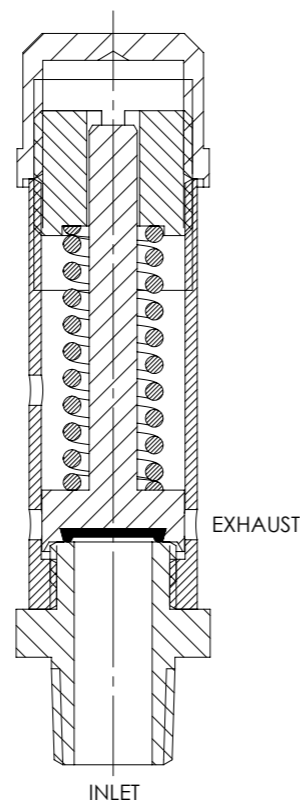

### Materials

Externally Exposed and Internally Wetted Parts: 316 and 302 stainless steel.

The standard valve is designed for use with air and plain water. Note that use with water above 100°C is not recommended. Other media compatible with the materials of construction may be used, although consideration must be given to the safety of such fluids when vented to atmosphere.

⚠ The standard valve has Viton® seals. Further seal options are available via the Product Selector. Compatibility with the working fluid at the operating temperature must be considered.

### Typical Performance

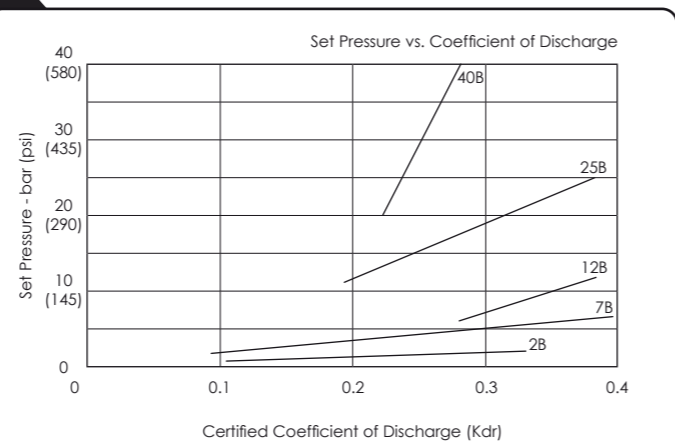

The Kdr value may be used to calculate discharge capacity in accordance with ISO 4126. We recommend contacting us with system details to confirm suitability.

### Installation Diagram

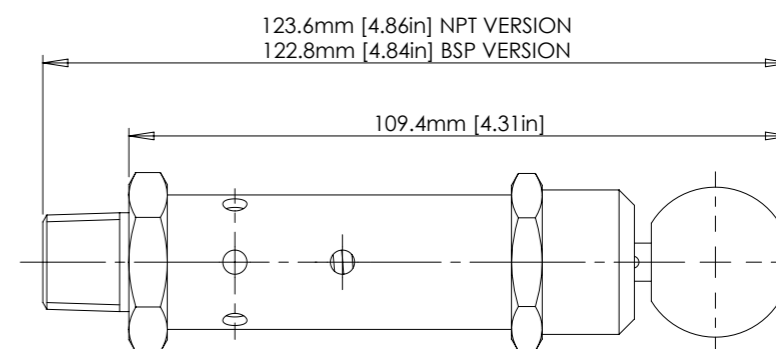
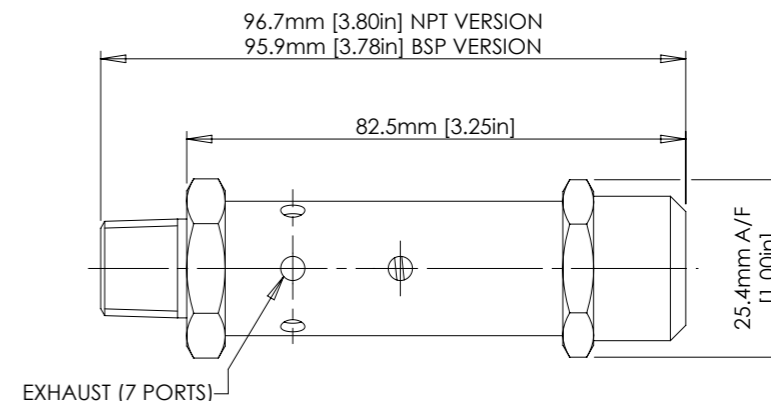
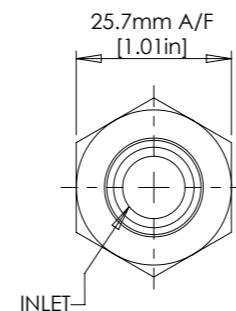
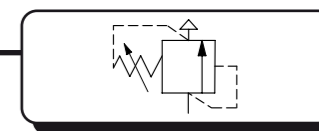

RG - RELIEVING GEAR OPTION

### Product Selector

**S37 P - RG - EP - 2B**

VALVE TYPE	PORTING OPTIONS	VALVE OPTIONS	SEAL OPTIONS	SET PRESSURE RANGE
<b>S37</b>	<b>P</b> 3/8" BSPP male	<b>RG</b> Relieving gear <small>Leave blank if not required</small>	<b>EP</b> EPDM seals -45°C to +150°C	<b>2B</b> 0.7 - 2 bar (10 - 29 psi)
	<b>N</b> 3/8" NPT male	<b>RG</b> Relieving gear <small>Exposure to high and low fluid temperatures will influence handle temperature. Operator safety must be considered.</small>	<b>NBR</b> Nitrile seals -30°C to +105°C	<b>7B</b> 2 - 7 bar (29 - 102 psi)
			<small>Further seal options are available on request</small>	<b>12B</b> 6 - 12 bar (87 - 174 psi)
			<small>The safety of venting high and low temperature fluids to atmosphere must be considered</small>	<b>25B</b> 11 - 25 bar (160 - 363 psi)
				<b>40B</b> 20 - 40 bar (290 - 580 psi)

Repair and seal kits are available on request  
For a seal kit add SK at the end of the model code and for a repair kit add RK



CATALOGUE ALSO AVAILABLE ON CD  
VISIT OUR WEBSITE FOR A FULL ONLINE SEARCH FACILITY  
[www.bisvalves.co.uk](http://www.bisvalves.co.uk)



**BIS VALVES**  
The Specifier's Catalogue Page ???

SOLENOID  
FLOW CONTROL  
3 PORT DIRECTIONAL CONTROL  
4 PORT DIRECTIONAL CONTROL  
CHECK AND SHUTTLE  
PILOT OPERATED CHECK  
RELIEF  
EXCESS FLOW  
FILTERS  
PRESSURE SENSING  
PUMPS  
ACTUATORS  
TECHNICAL DATA