

NR50 -20K CHECK VALVE

1/2" UP TO 1,379 BAR 20,000 PSI

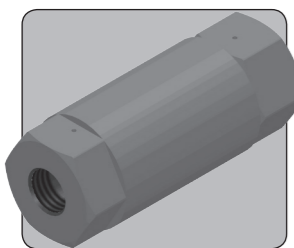

The NR50-20K is a 1/2" nominal bore check valve. It will allow flow in one direction, and blocks flow in the opposite direction. It may also be referred to as a non-return valve.

The valve uses sealed poppet technology to give virtually zero leakage with liquids and gases.

- Check or Non-Return valve
- Super duplex and stainless steel construction
- Sealed poppet design
- Virtually zero leakage
- Can be used subsea
- Suitable for liquid or gas
- Suitable for use with air, nitrogen, sweet natural gas, mineral oils, water glycols, water and sea water
- Suitable for many other media, contact us for advice
- NACE MR01-75 compliant version available
- High cracking pressure variants available, contact us for details
- Various seal options available
- Various porting options available

Specifications

BASIC MODEL NUMBER

NR50-20K

SYMBOL



MAX WORKING PRESSURE (LIQUID)

1,379 bar
(20,000 psi)

MAX WORKING PRESSURE (GAS)

690 bar
(10,000 psi)

CV (FLOW CAPACITY)

1.6

FLUID

Liquids and Gases
See materials section

TEMPERATURE RANGE

See Product Selector opposite
and Technical Data section

NOMINAL SIZE

1/2"

CRACKING PRESSURE

0.1 - 0.3 bar
(2 - 5 psi)

WEIGHT

1.6 kg
(3.5 lb)

Specifications may change without notice

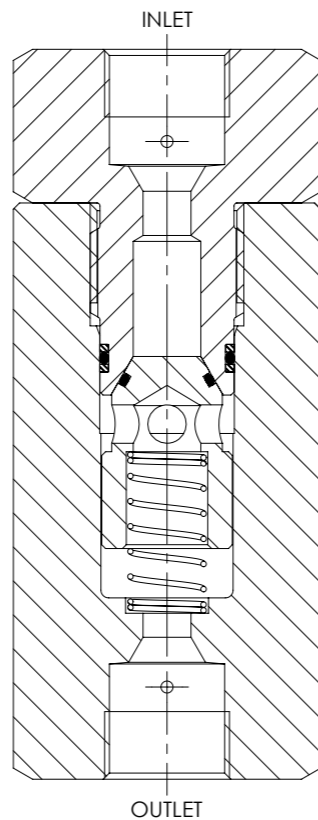

Materials

Externally Exposed Parts: Super duplex.
Internally Wetted Parts: Super duplex and 316 stainless steel with 302 stainless steel spring and PEEK. The spring is inconel for SWD and NACE variants.

The standard valve is designed for use with air, nitrogen, sweet natural gas, mineral oil, water glycols and plain water, and may also be used with a wide variety of media compatible with the materials of construction.

⚠ The standard valve has Viton® seals. Further seal options are available via the Product Selector. Compatibility with the working fluid at the operating temperature must be considered.

Typical Performance

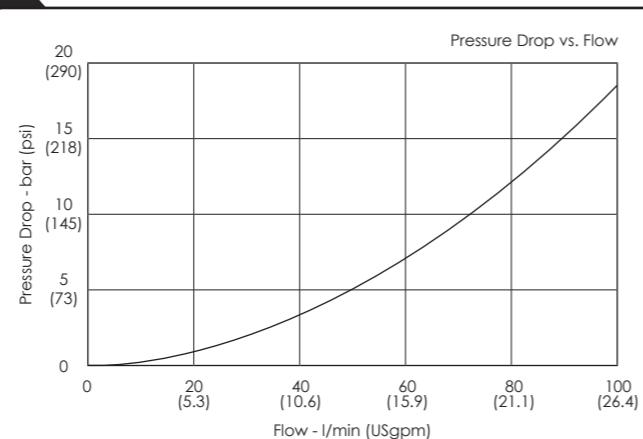

Typical performance based on water

Installation Diagram

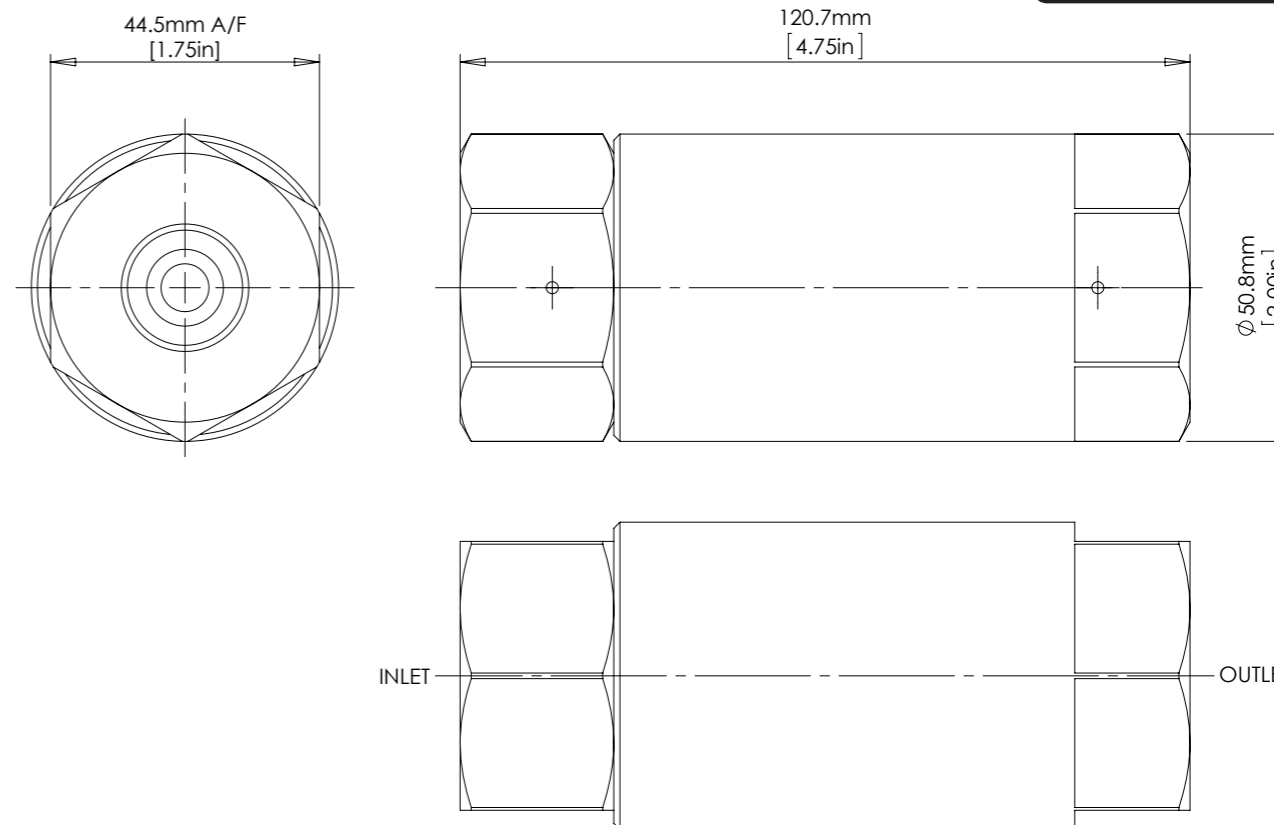

Product Selector

NR50 - 81AE - NBR - SWD - 20K

VALVE TYPE	PORTING OPTIONS	SEAL OPTIONS	VALVE OPTIONS	MAX WORKING PRESSURE
NR50	81AE 9/16" OD medium pressure tube port	Leave blank for Viton® seals -10°C to +160°C NBR Nitrile seals -30°C to +105°C EP EPDM seals -45°C to +150°C KLZ Kalrez® seals -25°C to +200°C HNBR Hydrogenated Nitrile seals -20°C to +150°C Further seal options are available on request	Leave blank if not required SWD Materials compatible with sea water NACE Materials comply with NACE MR01-75	20K 1,379 bar (20,000 psi) Liquid 690 bar (10,000 psi) Gas



Catalogue also available on digital media
 Visit our website for a full online search facility
www.bisvalves.co.uk

SOLENOID
STOP AND METERING
3 PORT DIRECTIONAL CONTROL
4 PORT DIRECTIONAL CONTROL
CHECK AND SHUTTLE
PILOT OPERATED CHECK
RELIEF
EXCESS FLOW
FILTERS
PRESSURE SENSING
PUMPS
ACTUATORS
TECHNICAL DATA