

CARTRIDGE RELIEF VALVE (H.P.) TYPE: PRV75C

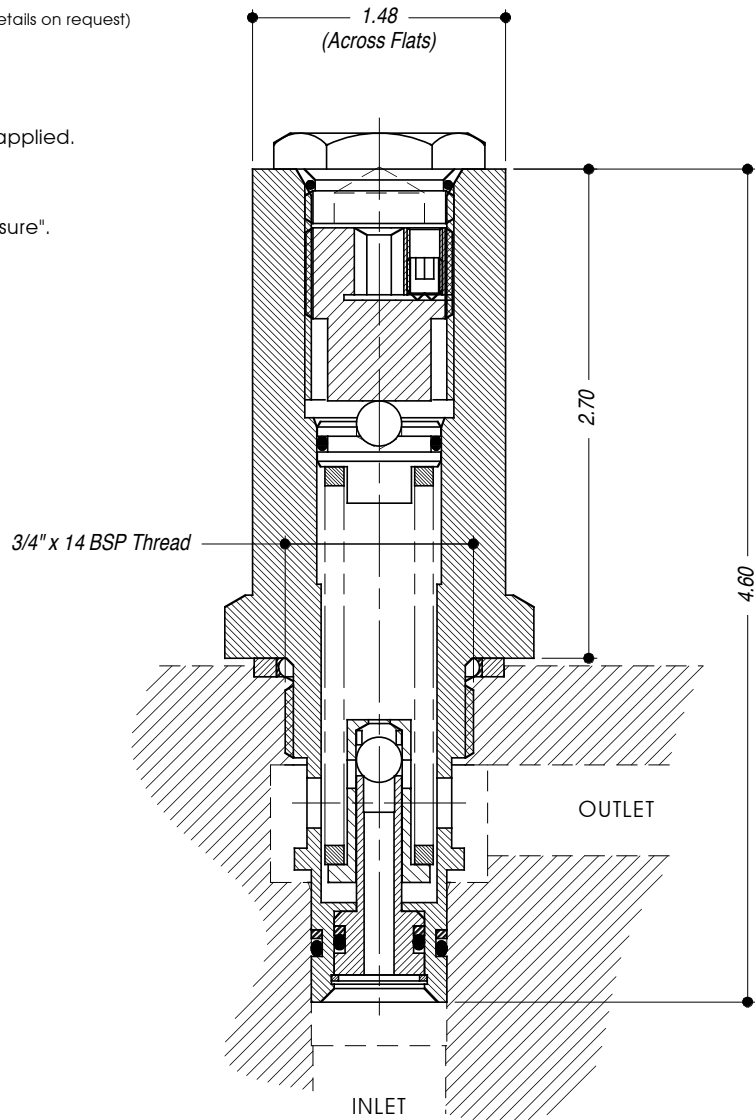

- **PRESSURE EQUIPMENT DIRECTIVE (PED) 2014/68/EU APPROVED.**
- **STAINLESS STEEL (316 / 1.4404)**
- **SUITABLE FOR LIQUID USE.**
- **FOR USE IN SUITABLE CAVITY HOUSING.** (details on request)
- **ALL DIMENSIONS IN INCHES.**

- Leaktight when 90% of "set pressure" is applied.
- Repeatability $\pm 5\%$ of "set pressure".
- Re-seating within 20% of "cracking pressure".
(Pre-set cracking pressure is optional)
State details when ordering.
- Recommended **MAXIMUM** back pressure 1,000 psi. (70 Bar).



Circuit Symbol

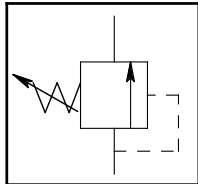

TECHNICAL SPECIFICATION		ORDERING EXAMPLE
Valve Type:	PRV75C	PRV75C
Working Media: (standard)	Oil / Water Glycol Duty (no ordering code req'd)	—
Press. Range:	1K - 3K psi 2.5 - 6K Max W.P.	3K
Orifice Size:	Ø4.1mm	
Valve Seat Mat'l: (standard)	Silver Steel KEA108 (liquid use)	
Seal Material:	Nitrile (other materials available by request)	
Dry Weight: (kg)	0.6	
Working Temperature Range:	-30°C to +105°C	
Flow Rate:	Contact factory for details	